

NUFLEX

FLEXIBLE GEAR COUPLINGS

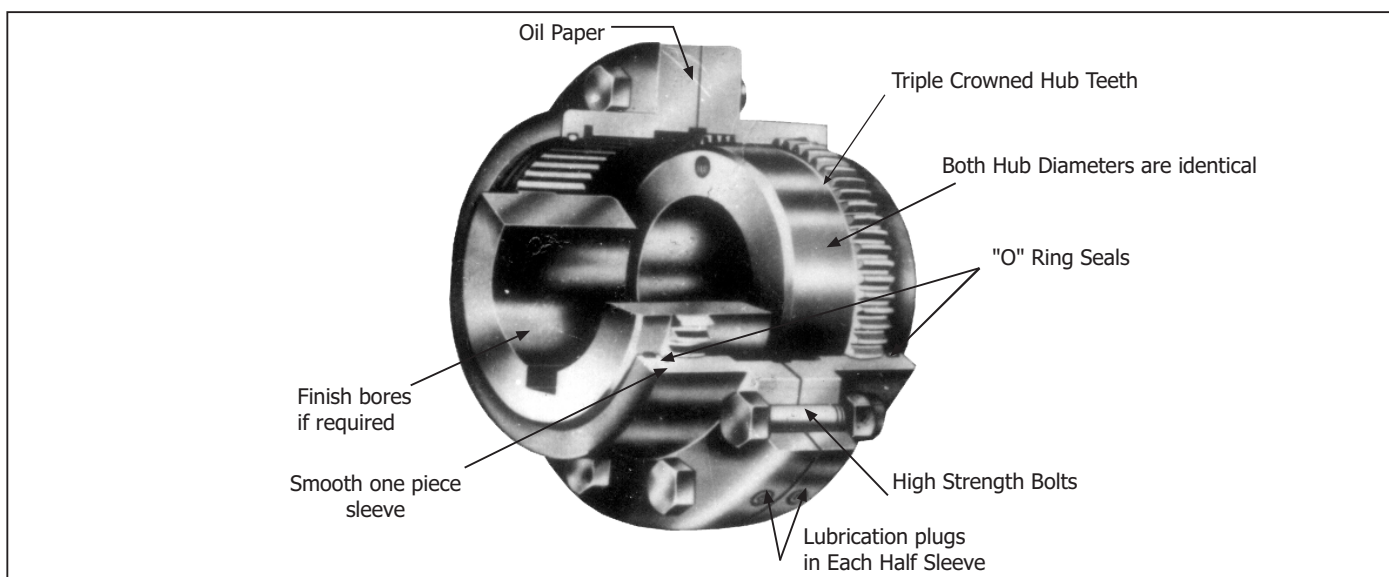

Under the misalignment condition of two shafts of the equipment, the teeth contact in case of straight cut hub will be as minimum as shown in the figure No. 1

Under heavy loads the ends of the hub teeth will get damaged resulting in the excessive play between hub & sleeve. And, therefore, the reduction in life of coupling.

NU-TECK TRIPLE-CROWNED TEETH

The triple crowned teeth hub is manufactured on a fully automatic hobbing machine with built in crowing attachment which is controlled by hydraulic & electronic systems.

Under the misalignment condition of two shafts on the equipment, due to the curvature on teeth flank the contact area is much more and therefore, there is increase in life of coupling.

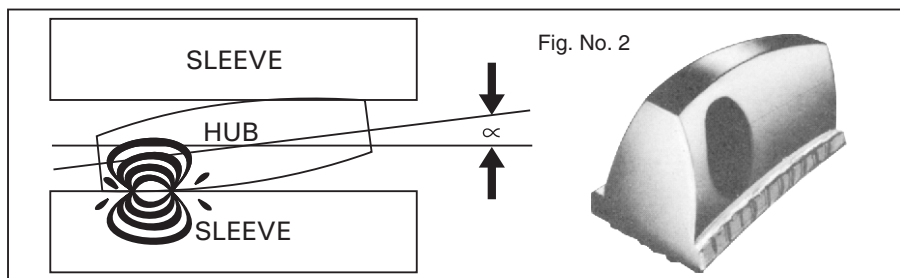
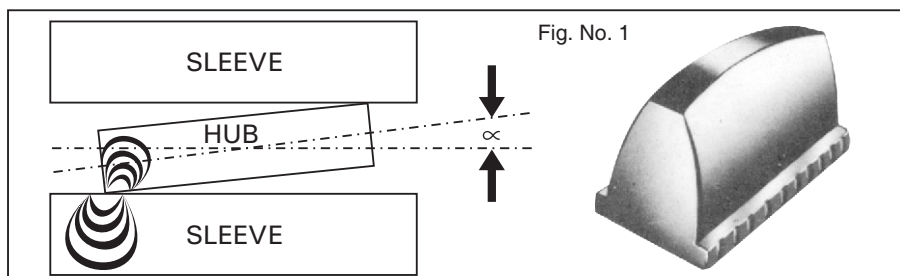

MISALIGNMENT DETAILS : In case of straight tooth gear coupling the maximum allowable angular misalignment (∞) is 1.1/2 deg. and in case of NUTECK Triple Crowned tooth Gear Coupling the misalignment is 7.1/2 deg.

SERVICE FACTORS

PRIMER MOVER

Driven Unit (Machinery)	Electric Motor or Steam Turbine	Gasoline or Diesel Engine 4 or more cyl.	Gasoline or Diesel Engine, more than 6 cyl.
LIGHT : Uniform or Steady load never exceeding horse rating, infrequent starting; Agitators, Blowers, Can Filling Machines, Conveyors, Fans, Generators, Pumps, Steering Gear, Stokers.	1.0	1.5	2.0
MODERATE : Heavy inertia, moderate shock, frequent starting; peak loads do not exceed 125 per cent average horsepower. Uneven load : Conveyors, Feeders, Welding, Laundry Washers, Mixers, Paper Mills, Printing Presses, Screens, Textile Industry, Car Pullers.	1.5	2.0	2.5
HEAVY : Heavy shock conditions or frequent reversing peak loads do not exceed 150 per cent average horse power. Uneven load. Cranes & Hoists, Crushers, Dredges, Elevators, Hammer Mills, Lumber Industry, Machine Tools, Metal Mills, Oil Industry, Rubber Industry, windlass.	2.0	2.5	3.0

NUFLEX FULL FLEXIBLE GEAR COUPLINGS

MINIMUM CLEARANCE REQUIRED FOR ALIGNING

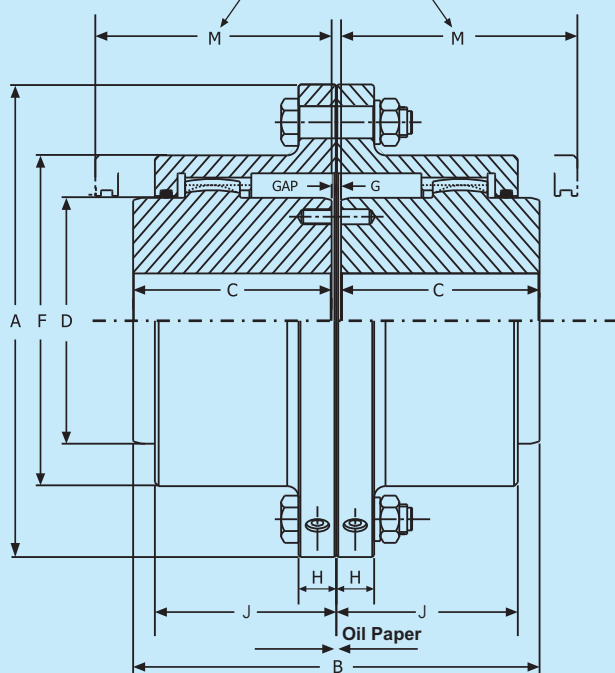

MINIMUM CLEARANCE REQUIRED FOR ALIGNING

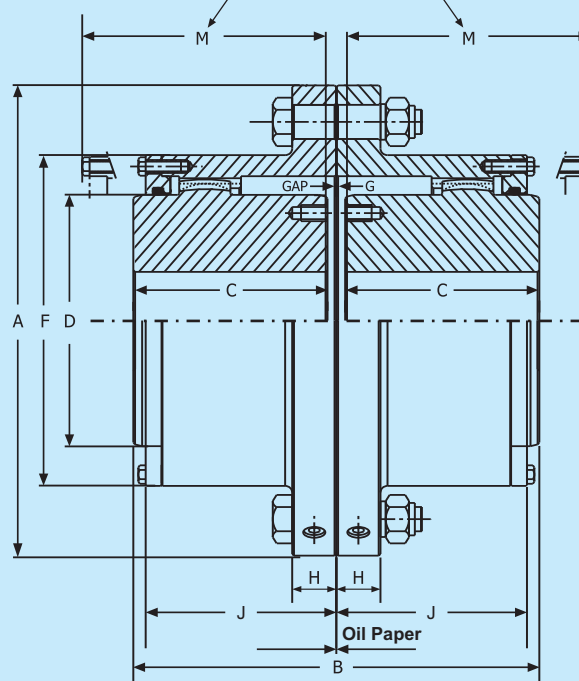

GC-100 TO GC 104

GC-105 TO GC 110

NU-TECK G. C. NO.	LOAD CAPACITY			BORE MIN.	BORE Max.	DIMENSION IN MM									WR ² Kgm ²	Wt. In Kg.
	H. P. CAPACITY AT 100 R.P.M.	Max. TORQUE Kg. M.	Max. R.P.M.			A	B	C	D	F	G	H	J	M		
GC-100	7	50	8000	12	32	120	93	45	50	75	3	15	40	55	0.03	4.5
GC-101	17	125	6300	20	45	170	115	55	65	110	5	17	49	65	0.14	11
GC-102	42	300	5000	30	60	185	145	70	85	125	5	17	62	80	0.20	15
GC-103	75	540	4000	40	75	220	175	85	105	150	5	20	78	105	0.48	25
GC-104	135	985	3350	50	90	250	215	105	130	175	5	20	96	125	0.95	39
GC-105	210	1505	2800	60	110	290	230	110	155	204	10	25	108	140	1.90	57
GC-106	325	2330	2500	75	125	320	260	125	175	235	10	25	118	155	3.00	85
GC-107	560	4000	2100	90	140	350	290	140	205	265	10	25	136	175	5.25	103
GC-108	720	5140	1900	105	160	380	320	155	230	295	10	25	149	190	8.50	138
GC-109	895	6400	1700	125	180	430	340	165	250	336	10	27	160	205	15.00	210
GC-110	1290	9225	1400	140	220	490	370	180	310	396	10	27	175	220	30.50	277

HOW TO SELECT THE RIGHT NUFLEX GEAR COUPLING

1. Select the size NUFLEX Coupling that will accommodate the diameter of the largest shaft. Usually this will determine the proper size Coupling for your application.
2. To make sure this Coupling has the required capacity : a) Check your application against the Service Factor Chart. b) Use the following formula to obtain the HP per 100 RPM of your application :
$$\frac{HP \times \text{Service Factor} \times 100}{RPM} = HP / 100 \text{ RPM}$$

NOTE : Dynamic balancing & Heat Treatment will be done on request.

Manufactured & Marketed by :



NU-TECK COUPLINGS PVT. LTD.

REGD. OFFICE & WORKS : B-1-C-13, BHOSARI INDUSTRIAL ESTATE, P.B. NO. 14, PUNE - 411 026 (INDIA)

• TEL. : 27120103, 27120104, 65337258, 65105294 • FAX : (020) 27121223 • E-mail : info@nuteckcouplings.com • Website : www.nuteckcouplings.com

OUR STOCKISTS

- | | |
|---|---|
| <ul style="list-style-type: none"> • AHMEDABAD : RAKESH ENTERPRISES :
L - 453, GIDC Estate, Odhav, Ahmedabad - 382 415, Tel. : 079-22870088, 22870085
E-mail : rakeshenterprise99@gmail.com • MUMBAI : DEEPAK ENTERPRISES :
Karmastambh, Unit No. G-D-8, Ground Floor, L.B.S. Marg, Vikhroli (W) Mumbai - 400 083
Tel. : 022-25770706 Fax : 25702975 E-mail : deepak_ent@yahoo.com • DELHI : DEL-KAYESS INDUSTRIAL SERVICES :
5574-A/17 & Kansiram Market, New Chandrawal, (Opp. 18 F Kamalanagar) Delhi - 110 007
Tel. : 011-23858804, Telefax : 23856823 E-mail : deljayess@gmail.com | <ul style="list-style-type: none"> • SECUNDERABAD : COMMERCIAL ENGINEERING CORPORATION :
3 Aziz Mansion 5-5-83 Ranigani, Secunderabad - 500 003.
Tel. : 040-27714574, 27710272 E-mail : cecbkg@gmail.com • CHENNAI : SHREE SYSTEM ENTERPRISES :
"Shubhshree" H-26, Central Avenue, Korattur, Chennai-600 080
Phone : 044-26257205, 26252219 Fax : 044-26357379
E-mail : jeevandos@gmail.com |
|---|---|

www.nuteckcouplings.com